



BEVERAGE-AIR

Project: _____	AIA#
Item: _____	
Location: _____	SIS#
Approved: _____	

BAR EQUIPMENT- BACK BAR REFRIGERATOR

MODEL:
BB48HC-1-G-B

BB48HC Glass Door
Hydrocarbon Series

BB48HC BACK BAR REFRIGERATOR

5 Year Parts/Labor Warranty Available
7 Year Compressor Warranty



CABINET CONSTRUCTION

- Exterior features durable black painted steel
- Interior construction utilizes galvanized steel on walls and ceiling, heavy duty stainless steel floor
- Full electronic control
- Galvanized sub-top standard
- Self-closing doors with 120° stay-open feature
- Field reversible doors (hinge kit not included)
- Door locks
- Magnetic door gaskets provide positive door sealing
- LED lighting
- Packaged products only
- Four (4) epoxy coated wire shelves
- Compressor available on left or right, specify at time of unit order
- Balanced, forced air refrigeration system provides rapid chilling of product

OPTIONS & ACCESSORIES

- 3 Year parts/labor standard, additional 2 year warranty available
- For stainless steel interior (refer to -F models)
- 2" Stainless steel top
- Wine model (40°-60° models)
- Wire shelf divider
- Additional shelves
- Additional shelf clips
- 3" or 6" Casters
- 6" Black legs
- Remote option* (see note on back on page)

REFRIGERATION SYSTEM

- Uses environmentally friendly, energy efficient R290 refrigerant, and meets all regulatory requirements for CARB, SNAP, DOE & more
- Adaptive defrost
- Epoxy coated evaporator coil
- Maintains product temperature between 36°F and 38°F



Please verify qualifying units by visiting:
www.energystar.gov/cfs

3779 Champion Blvd., Winston-Salem, NC 27105
1-888-845-9800 Fax: 1-336-245-6453
Beverage-Air.com Sales@bevair.com



BEVERAGE-AIR

MODEL	BB48HC-1-G-B
EXTERNAL DIMENSIONAL DATA	
Width Overall	48"
Depth Overall	24 1/2"
Height Overall	34"
Number of Doors	2
Depth with Door Open 90°	41 1/4"
Door Opening (in)	16 1/2" x 29 1/4"
INTERNAL DIMENSIONAL DATA	
NET Capacity (cubic ft.)	12.4
Internal Width Useable (in)	36 1/8"
Internal Depth Overall (in)	19"
Internal Height Overall (in)	29 1/2"
Number of Shelves	4
Number of 1/2 Kegs	2
ELECTRICAL DATA	
Full Load Amperes	2.5
REFRIGERATION DATA	
Horsepower	1/4
Capacity (BTU/Hr)	1702
Heat Rejection (BTU/Hr)	2553
Charge (lbs/grams)	0.1984/90
SHIPPING DATA	
Gross Weight - Crated	286 lbs
Height - Crated	43"
Width - Crated	51"
Depth - Crated	27"

*NOTE: Remote units are field wired and come with 6" legs.
Refrigerant must be specified at time of order.

Bar Equipment-Back Bar Refrigerator Model: BB48HC-1-G-B

Model Views

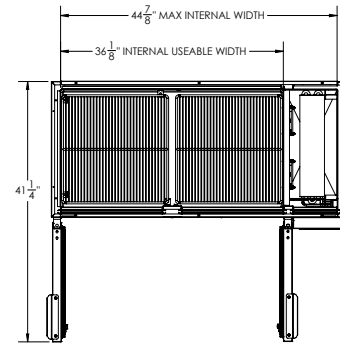

PLAN VIEW

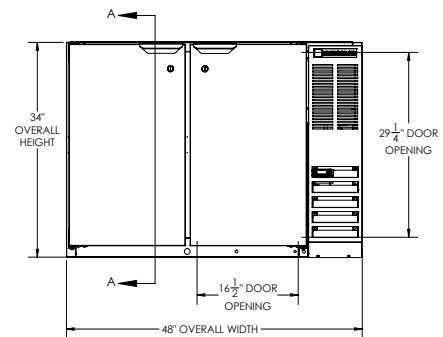

ELEVATION VIEW

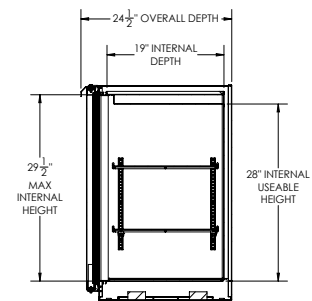

SIDE VIEW



ELECTRICAL CONNECTION

115/60/1
NEMA 5-15P

Unit pre-wired at factory
and include 8' long cord
and plug set.